

# Building Blocks for DNA Self-Assembly

Yuriy Brun, Manoj Gopalkrishnan, Dustin Reishus, Bilal Shaw,  
Nickolas Chelyapov, and Leonard Adleman

Laboratory for Molecular Science  
University of Southern California  
Los Angeles, CA 90089-1340  
{ybrun, gopalkri, reishus, bilalsha, chelyapo, adleman}@usc.edu

**Abstract.** DNA complexes, like the double crossover, are used as building blocks for the assembly of higher-order structures. Currently, the number of experimentally proven reliable complexes is small. We have begun work on expanding the collection of such complexes. Here we report on our design concepts and initial experiments. In particular, we present experimental evidence of two new complexes: quadruple crossovers and triangles. In principle, quadruple crossovers can be extended to three-dimensional, space-filling lego brick complexes, while triangles are capable of hexagonally tiling the plane.

## 1 Introduction

We explore new DNA complexes based on existing motifs that experiments have shown to be reliable. We present two paradigms for designing such complexes: the “crossover paradigm” and the “polygon paradigm”. The crossover paradigm, derived from double and triple crossovers, is used for the design of complexes with an arbitrary number of parallel double helices, while the polygon paradigm is used for the design of n-sided complexes with n sticky ends.

Two 8-sequence DNA complexes, the quadruple crossover and the lego<sup>®</sup> brick are examples arising from the crossover paradigm. The quadruple crossover, a straightforward generalization of the triple crossover, is used to tile the plane, while the lego brick is designed for eventual use in filling a three-dimensional space. Section 5.1 discusses our experimental results with the quadruple crossover complexes.

The triangle is a 5-sequence DNA complex that arises from the polygon paradigm. It assembles into a hexagonal tiling of the plane. Section 5.2 discusses our experimental results with this complex.

The remainder of this paper is organized as follows. We review work related to ours in section 2, present the paradigms in section 3, describe the materials and methods used in our experiments in section 4, discuss our experimental results in section 5, and conclude and discuss future work in section 6.

## 2 Related Work

Branched nanostructures assembled of DNA appeared as early as 1990 [2]. Seeman et al. used solid support based methodologies in order to construct a variety of structures topologically equivalent to polyhedra such as octagons, and cubes and even Borromean rings. To date, assembly of regular rigid three-dimensional lattices has not been experimentally demonstrated [12].

Winfree and Seeman [19] built regular, patterned crystal lattices out of DNA complexes called double-crossovers (DX) that were related to Holliday-junction that occur naturally during meiosis.

A DX complex can be thought of as two rigid double helices connected at two locations via individual DNA strand crossovers. There are variations of the DX complex, but for the purposes of this discussion we will consider the DAO and DAE motifs. This nomenclature was devised by Seeman [8]; D refers to double, A to anti-parallel, and O or E to the odd or even number of half turns between crossovers. The DAO motif contains four sticky ends, or single stranded regions of DNA. The arrangement of the four sticky ends around the DAO complex determines the kind of pattern the complex generates. Winfree et al. [19] designed an arrangement of the sticky ends that staggered the DAO complexes. The connection between neighboring DAO complexes is achieved via Watson-Crick base pairing. It is worth mentioning that the sticky ends of the DAO complex were not self-complementary. Two different DAO complexes, with their respective sticky ends complimentary, formed a lattice. The longest strand was 48 nucleotides long and the shortest strand was 26 nucleotides long. The dimension of each DAO complex was approximately 12.6 nm x 4 nm. An atomic force microscope (AFM) was used to visualize these lattices, supporting the existence of crossover complexes as well as the formation of aperiodic lattices. Winfree et al. also attached a DNA hairpin molecule to a specific site on one of the DAO complexes (DAO + 2J), to produce a patterned lattice that appeared as light and dark bands under the AFM. The largest lattices were several microns across.

Soon after Winfree et al.'s work with the DX complexes, LaBean et al. constructed triple crossover (TX) complexes [6]. TX complexes consist of three double helices, connected via crossovers of strands at four different sites. Eight strands participated in the formation of TX, and as in Winfree et al.'s work, a separate motif (TX + 2J) placed a hairpin at a specific site to produce a patterned lattice appearing as light and dark bands under an AFM. The TX is particularly interesting because it has the potential for six sticky ends. However, LaBean et al. used only four sticky ends, leaving out the two sticky end regions on the middle double helix. The TX complexes produced the same staggered arrangement as Winfree et al. had produced with DX complexes. AFM images revealed TX lattices several microns across.

Seeman et al. [13] constructed a parallelogram grid using Holliday junctions. They produced rigid rhombus motifs using branched DNA junctions that self-assembled into a two-dimensional parallelogram array.

Yang et al. [22] first constructed a rigid triangle motif. The triangle motif attaches to a DX complex along one side of the triangle, allowing the self-assembly of triangles via connections made between the DX complexes. Triangles alternate on either side of a single long double helix. One of the drawbacks of the triangle motif is

that one of the DNA strands is 280 nucleotides long. While one can synthesize such long strands, the yield rates are generally very low. Nonetheless, the research paved the way for others to think about constructing higher order rigid polyhedral motifs.

Mao et al. [7] constructed DNA triangles with flexible four-arm DNA junctions. They produced one-dimensional and two-dimensional lattices several microns across. At equilibrium, the angles between the nanotriangles' arms are approximately  $60^\circ$ , thus the triangles are equilateral.

John Reif's group at Duke University constructed 4x4 DNA lattices [21]. Note that all the motifs discussed so far, including the 4x4 complex, are variations of branched Holliday junctions. At first look, the 4x4 complex appears different from the DX complex, but a closer inspection reveals that a 4x4 complex is two DX complexes spliced in the middle and laid perpendicular to each other. The 4x4 consists of nine different DNA strands, the longest strand of 100 nucleotides and the shortest strand of 13 nucleotides. The 4x4 is self-complementary where the north end is complementary to the south end of the complex and the east end is complementary to the west end. A single type of 4x4 complexes can tile a plane. AFM analysis reveals the 4x4 complexes form a regular grid several microns across.

Winfrey bridged the fields of DNA computing and DNA nanotechnology into what he later termed algorithmic self-assembly of DNA [17]. He showed that double crossover complexes can act as practical analogs to Hao Wang's mathematical tiles [16]. Winfree also proved that the tile assembly model is computationally universal. Therefore a tile assembly can solve any problem using double crossovers that any conventional computer chip can solve. Winfree's group proceeded to compute Pascal's triangle, modulo 2, using DNA [18]. In fact, Pascal's triangle, modulo 2, generates the Sierpinski triangle, a fractal. LaBean et al. [6] performed the exclusive or (XOR) calculation using TX tiles. DNA string tiles [20] can also compute exclusive or.

Seeman proposed building programmable self-assembled DNA structures [1]. A layer consisting of DNA tiles self-assembles to allow additional layers to assemble on top. The bottom layer acts as a template that allows assembling tiles of the second layer to associate in certain order. The result is a self-assembly computation programmed by the template. Templates can also consist of more than a single layer. Multiple template layers can speed up computations by computing in parallel. Computation can be carried out in multiple dimensions by using complexes that assemble to fill a three-dimensional space.

Three-dimensional DNA self-assembly allows the construction of scaffolds that could mediate the interaction of proteins. Scaffolds can also regularize proteins in a lattice, allowing X-ray crystallography, eliminating the need to directly crystallize proteins [9].

Seeman discusses "reciprocal exchange," the design principle that allows the creation of DX and TX complexes. Reciprocal exchange consists of crossings of DNA strands between two double helices [11]. Figure 1 shows an example of reciprocal exchange. Performing a reciprocal exchange of strands between two double helices at every crossing point, known as a zero node, results in the paranemic motif (PX) [11]. Other techniques borrowed from topology and knot theory, such as zero node removal, lead to complex fused motifs [10]. A knot with a zero node inserted at a reciprocal exchange point leads to a branching motif.

### 3 Design Paradigms

#### 3.1 Crossover Paradigm

The crossover paradigm uses two reciprocal exchanges [11] per pair of adjacent DNA helices to join them. In this way, two complexes of double stranded DNA can be tied together at two points. Figure 1 shows an example of two helices connected with a single reciprocal exchange. With one crossover point, the two helices are still free to rotate around that point. Two or more crossover points between two helices appear to ensure rigidity. DX complexes use this approach to achieve rigidity. Different locations along the helices for the crossover points result in different DX motifs.

The TX complex is based on the same paradigm. It is created by taking a DX complex and adding two additional crossover points between one of the helices in the DX complex to an additional DNA helix.

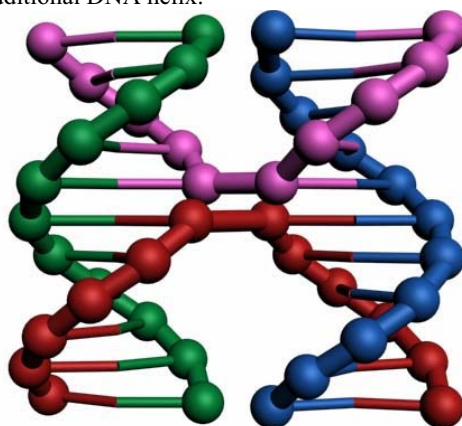

Figure 1. An example of a reciprocal exchange. Two DNA helices are connected by sharing two DNA strands

One of the goals of our work is to create regular three-dimensional lattices. The main challenge in creating three-dimensional lattices is that existing DNA self-assembled units are all planar. The DX, TX, 4x4 and their variants have all their DNA helices constrained to one plane. We wanted to employ the crossover paradigm to create a complex that did not have all its DNA helices in one plane. We are attempting to create such a complex by taking four double helices of DNA and assembling them as a lego brick, as shown in Figure 2. This is a modified version of the fused double crossover proposed by Winfree and Rothmund [18]. The lego brick is two double-crossovers, one on top of the other, with four additional crossover points between them. In the figure, the dashed lines represent the crossover points. Note that there is no base pairing along the dashed lines; all base pairing occurs along

the solid lines. Two adjacent solid lines represent B-form double stranded DNA. The result is four double helices, arranged as four parallel edges of a cube.

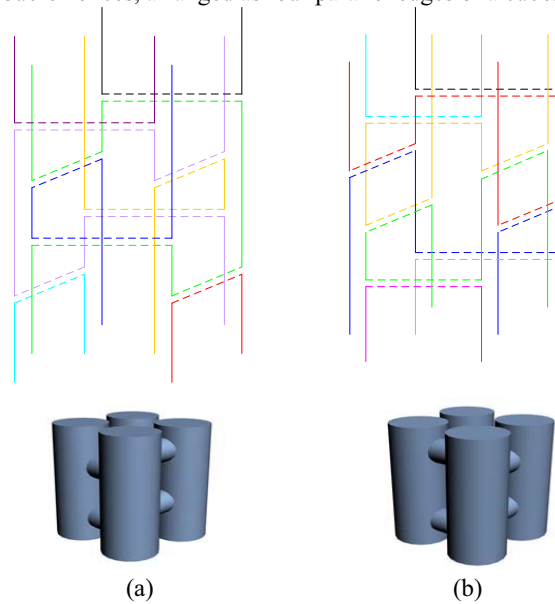

Figure 2. Two distinct lego brick motifs. Note that there is no base pairing along the dashed lines; all base pairing occurs along the solid lines. Two adjacent solid lines represent B-form double stranded DNA

The lego brick is an example of how to utilize the crossover paradigm to create complexes with a desired form – in this case, four double helices arranged in a square. Crossover points are placed between every two adjacent helices. In principle, one may connect each helix to as many as six other parallel helices at crossover points. In this example, however, each helix is only connected to two other helices via crossover points. The location of the crossover points is determined according to three constraints. First, we want to minimize the number of separate DNA strands used for each unit. Second, we want to minimize the length of each of the DNA strands. Third, within each lego we want to maintain  $180^\circ$  rotational symmetry about the axis of the helices, as shown in Figure 2.

There are two distinct motifs that can form the lego brick. These motifs differ in the location of the additional crossover points. Each satisfies the two above constraints. The new crossover points can interleave the existing ones, shown in Figure 2a, or surround them, shown in Figure 2b.

In theory, the lego brick can be used to create one, two, or three-dimensional structures by appropriate changes of sticky ends. In all cases, it is possible to have each unit connected to its neighbors by at least two sticky ends. Figure 3 shows how lego bricks might form a line, tile a plane, or fill a three-dimensional space.

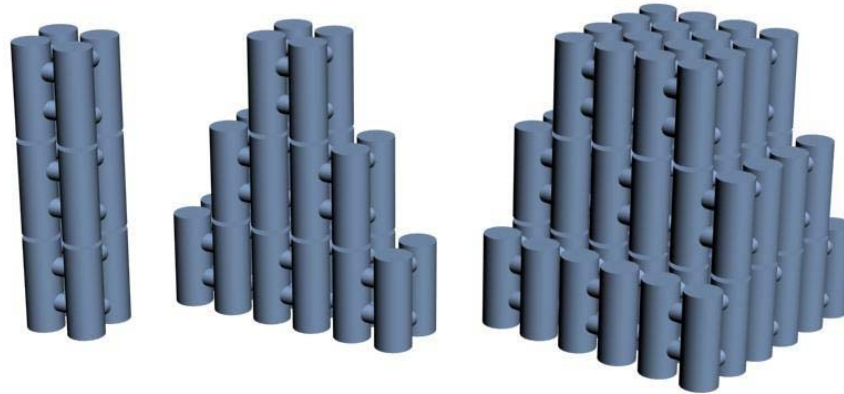

Figure 3. In theory, lego bricks can create a line, tile a plane, or fill a three-dimensional space

As a first step toward creating the lego brick, we created the quadruple-crossover complex (QX). The QX is a planar version of the lego brick. It extends the idea behind the DX and TX and consists of eight strands of DNA in four double helices. Each helix connects to its neighbors by two crossover points, as shown in Figure 4. The QX can be extended to the lego brick by adding two additional crossover points connecting the two outside helices.

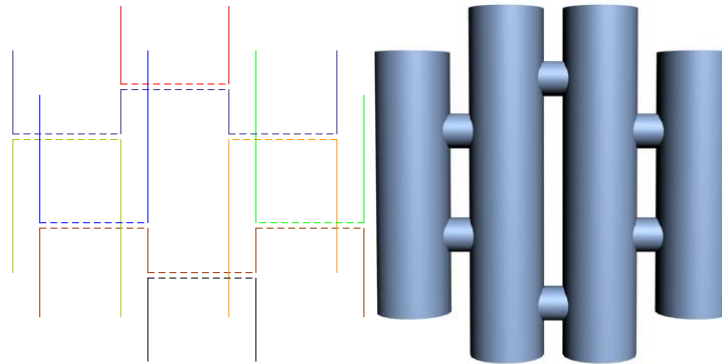

Figure 4. Quadruple crossover consists of eight strands, interweaving to form four parallel double helices. Note that there is no base pairing along the dashed lines; all base pairing occurs along the solid lines. Two adjacent solid lines represent B-form double stranded DNA

### 3.2 Polygon Paradigm

The polygon paradigm gives rise to  $n$  sided polygons with  $n$  sticky ends. The ends can be designed so that the polygons interconnect. There are three types of components in a polygon motif: a central core strand, side strands, and “horseshoe” strands. For each  $n$ -sided polygon there is a single central core strand,  $n$  side strands, and  $n$  horseshoe strands. For the structures the polygons assemble to be rigid, the polygons themselves must be rigid, and the connections between polygons must be rigid. Each arm of a polygon is itself a double crossover complex made of two double helices. The  $4 \times 4$  complex uses double crossover-like complexes for its four arms [21], and is an example of the polygon paradigm. Figure 5 shows instantiations of the polygon paradigm for  $n = 2, 3, 4$  and  $5$ . The central core strands are marked in black, side strands in red, and horseshoe strands in blue. Note that the two-sided design is identical to the DAE complex. Also note that the horseshoe strands may be recessed (as shown in Figure 5), or protruding.

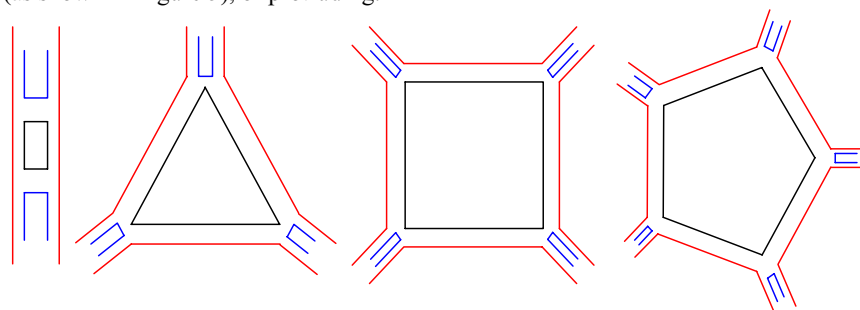

Figure 5. Examples of the polygon paradigm designs for  $n = 2, 3$  (triangle),  $4$  (square), and  $5$  (pentagon). The central core strands are marked in black, side strands in red, and horseshoe strands in blue

A triangle self-assembling DNA motif is capable of tiling a plane with a regular hexagonal pattern. Double crossover [19], triple crossover [6], and quadruple crossover complexes fill the plane;  $4 \times 4$  complexes [21] form a quadratic grid tiling. Tiling a plane with triangular units creates a hexagonal pattern much like a honeycomb. Figure 6a shows two triangle complexes with complementary sticky ends coming together to form a hexagon. The two triangle complexes differ only in their sticky ends and are represented in different colors. Figure 6b shows a hexagonal tiling of the plane.

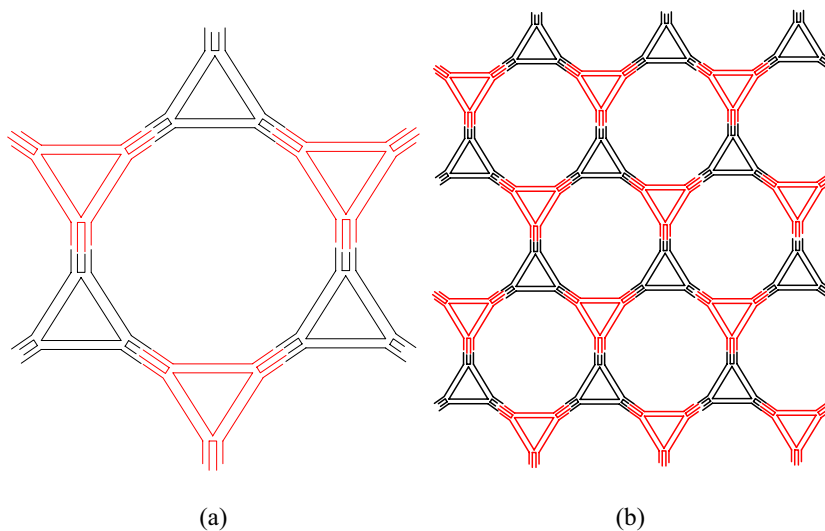

Figure 6. Triangle complexes forming hexagons. Six triangles with two different types of sticky ends (represented with different colors) form a single hexagon (a). Triangles can, in principle, tile an entire plane (b)

Although triangles can form a hexagon tiling of the plane when six triangles come together (Figure 6b), it is possible for any other even number of triangles to come together to form less energy favorable structures. The angles in the triangle complexes are such that it is natural for six triangles to assemble; however, other structures may form when other even numbers of triangles connect, straining the arms of the triangles and changing the angles between the arms. For example, four triangles can come together to form square structures as shown in Figure 7. These formations will not be as stable as the hexagonal formations, since the stress requires extra energy to keep the complexes together. Experimentally, we expect to get a range of formations, mostly, but not exclusively, hexagons.

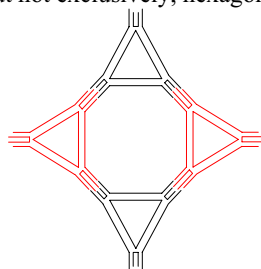

Figure 7. An alternative triangle formation. Four triangles may connect, causing stress in the arms, changing the angles between them or between their connections. Triangles may create squares, or other even-sided polygons



## 4 Methods and Materials

The methods used to generate AFM images for this paper are based on those used by Winfree et al. [19].

### 4.1 DNA Sequence Methods and Materials

We generated sequences to minimize unintentional inter- and intra-complementarity between DNA strands. Integrated DNA Technologies (IDT) [5] synthesized the DNA strands and purified them using polyacrylamide gel electrophoresis (PAGE). Each strand has the final concentrations of  $0.2\mu\text{M}$  in TAE/ $\text{Mg}^{2+}$  buffer. We prepared the TAE/ $\text{Mg}^{2+}$  buffer using 40mM Tris-HCl (pH 8.0), 1 mM EDTA, 12.5 mM  $\text{Mg}^{2+}$ . We annealed the solutions by keeping them at  $90^\circ\text{C}$  for 5 minutes and then cooling them to  $25^\circ\text{C}$  over the course of 65 minutes, 1 degree per minute, in a GeneAmp polymerase chain reaction (PCR) thermocycler.

### 4.2 AFM Sample Preparation and Imaging

We spotted  $5\mu\text{l}$  of the annealed DNA sample onto freshly cleaved mica (Ted Pella [15]) and left it to adsorb for 30 seconds. We topped the sample with  $25\mu\text{l}$  of 1X TAE/ $\text{Mg}^{2+}$  buffer. We performed imaging in tapping mode in a fluid cell using a J scanner and  $200\mu\text{m}$  cantilevers with  $\text{Si}_3\text{N}_4$  tips on a Multimode Nanoscope IIIa atomic force microscope (Digital Instruments [3]).

### 4.3 Sequences Used in Experiments

This section lists all DNA sequences used in the experiments whose results are shown and discussed in section 5. All sequences are shown 5' to 3'.

#### 4.3.1 Quadruple Crossover

Eight strands:

```
GAAAGTGGGAGGTGGAAATGAGTTGA
CTTCTTGGCAGACATTATTAATTTGGTGAGGGCTAC
CCTCACCAGAACGACGACAACATCCGAATAGCAAAACAATTTAACCTCCCA
TCATTTCCATAATCCATCTTCTTTTCACGCACCTATATCTCCTAGTCTGCCA
TATGCTTGGTCGTGTGAAAAGGAAGATGGTAGGAGATATAGGTGCGTTGCTAA
TTGCGCTCGATGTTGTCGTTCATTGTTTGGCTATTTCGGCTGTTTACGTCT
CTTCTTAGCAACACGACACAGCGAGCGCAATCAAC
AGAAGAGACGTAACAAGCATAGTAGC
```

### 4.3.2 Triangle

Five strands:

```
ATCCGGATGAGTAGTTGGGCTCAGTCGGAG
TGTTCGTTGGCGCT
GACTGAGCCCATGCTCACTGGACGAATCCGCAACTACAGGAACTACTCATCC
GGATAGCGCCATGCTCACTGGACGAATCCGCAACTACAGGAACGAACACTCC
TTCGTCCAGTGAGCATCCTGTAGTTGCGGATTCGTCCAGTGAGCATCCTGTAGTTGCGGATTCG
TCCAGTGAGCATCCTGTAGTTGCGGA
```

## 5 Results and Discussion

### 5.1 Quadruple Crossover

The AFM images, shown in Figure 8, depict the quadruple crossover lattice. The lattice was created from a single QX tile type. Figure 8a, a 250×250nm scan, shows lattices formed by QX complexes, while Figure 8b, an 800×800nm scan, shows tube structures formed by QX complexes. Individual tiles, as well as lattice defects, are clear in Figure 8a. Each of the tiles in the image is approximately 10nm wide and 17nm long.

It is possible to see internal structure within individual tiles, i.e. in Figure 8a it is possible to see holes in the center of the tiles. These holes likely arise because the crossover points between the two central helices are farther apart than the crossover points between the other helices, as shown in Figure 4. In the upper right corner and center of the left side of Figure 8a, one can see striations in each individual tile. These striations could indicate the major groove of the DNA helices.

As with DX, TX, and 4x4 tiles, the QX form long tubes, shown in Figure 8b. These tubes have a smaller diameter than those formed by DX, TX, and 4x4 tiles. Tubes that have broken open show that they are two tiles in circumference.

We are currently experimenting with lego bricks, but do not yet have sufficient data to experimentally validate the lego design.

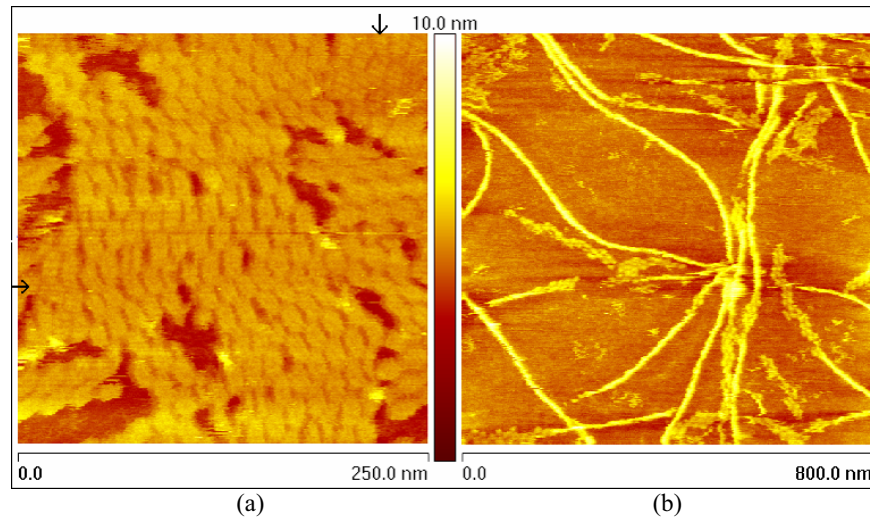

Figure 8. AFM images of quadruple crossover structures. A lattice of QX tiles (a) and QX formed tubes (b)

## 5.2 Triangles

Figure 9 shows three views of the hexagonal tiling of the plane. In Figure 9a, a  $99.2 \times 99.2$  nm scan, there are six triangles coming together to form a single hexagon. The structure of the individual tiles is clear as a triangle with three small arms. The hexagon is 60 nm in diameter in the cross-section. Figure 9c, a  $132.8 \times 132.8$  nm scan, shows two hexagonal tilings of the plane, one on top of the other. The hexagons rest in two layers, settling the top layer's triangles into the grooves created by the bottom layer hexagons. In our experience, this overlaying structure is a very common one for triangles to form. Figure 9b, a  $468.7 \times 468.7$  nm scan, shows a large view of layers of hexagons. The triangles form a hexagonal tiling as large as half a micron per side. The brighter areas of the image indicate that layers of triangles are stacked in that area to create additional height.

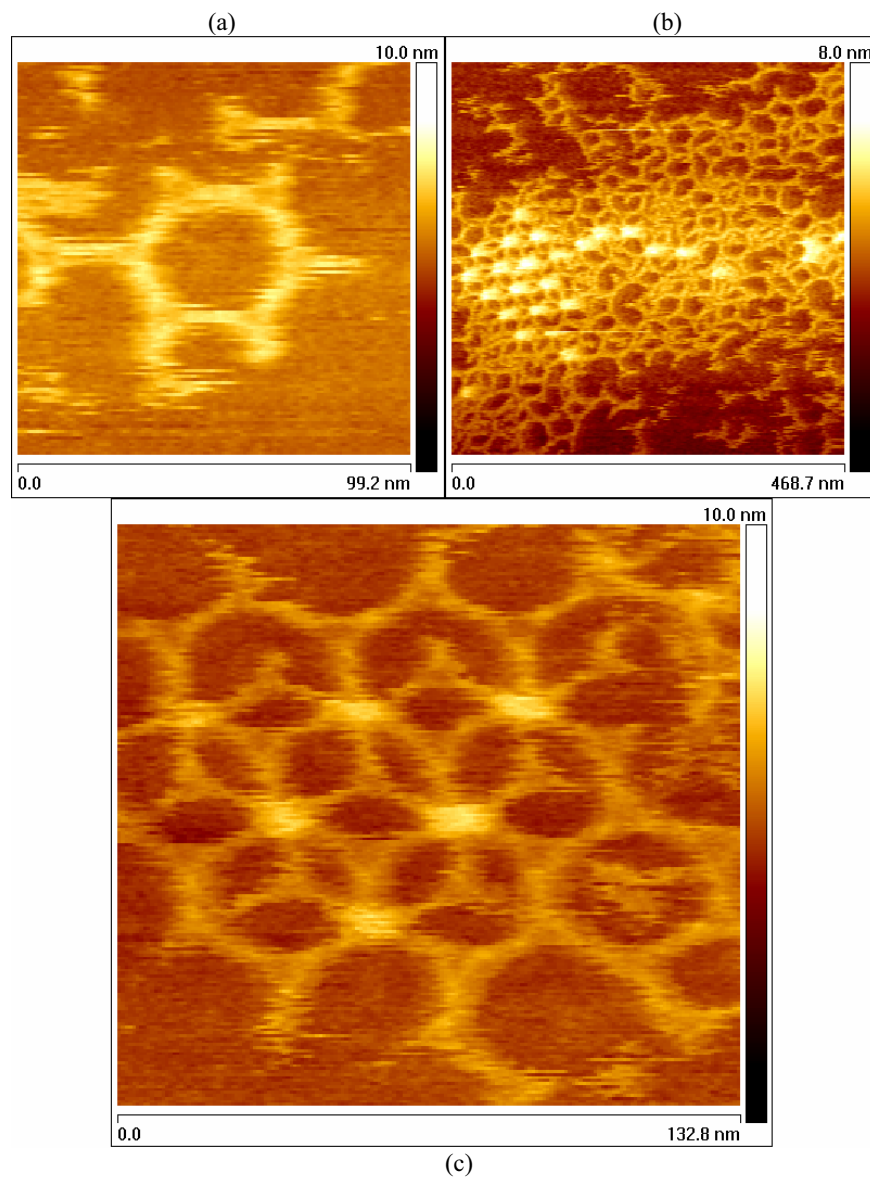

Figure 9. AFM images of triangle structures. Six triangles forming a hexagon (a), triangles forming stacked hexagonal lattices (b), and two layers of hexagonal lattice (c)

The experimental evidence supports the formations of triangle complexes, and the combination of triangle complexes to form the hexagonal tiling of the plane, as hypothesized in section 3.2.

## 6 Conclusions

In this paper, we explored two paradigms for generating reliable DNA complexes for use in self-assembly. Our goal was to expand the library of complexes used to create new classes of structures. In particular, we were interested in creating three-dimensional structures.

In our explorations, we defined two paradigms for creating DNA complexes, the crossover paradigm and the polygon paradigm.

We used the crossover paradigm to design a quadruple crossover complex and the lego brick. Experimentally, we found the quadruple crossover complex form structures including tilings of the plane and tubes. We believe that the motif can be extended to create quintuple and sextuple crossover complexes. A limiting factor in creating larger crossover complexes is the length of the DNA strands required for assembly. We have been unable to verify experimentally the formation of lego bricks; however, we are actively pursuing further experiments. Formation of lego bricks is one approach to building regular, rigid, three-dimensional DNA structures.

We applied the polygon paradigm to design the triangle complex and experimentally verified its formation. In our experiments, the triangles formed hexagons, which, in principle, are capable of tiling the plane. We believe, based on our results and previous work, that polygon paradigm can be used to create five- and six-sided structures, and possibly extended to even larger complexes. Further, the paradigm can be extended to create non-equilateral polygons by altering the lengths of the side strands.

## Acknowledgements

We thank Erik Winfree, John Reif, Thom LaBean, Paul Rothmund, and Nick Papadakis for discussions, comments, and teaching us AFM techniques.

## References

1. Carbone, A., and Seeman, N. Circuits and programmable self-assembling DNA structures. Proceedings of the National Academy of Science (PNAS), Volume 99, No. 20, pp. 12577-12582, October 1, 2002.
2. Chen, J. and Seeman, N.C. The synthesis from DNA of a molecule with connectivity of a cube. Nature 350, 631-633 (1991).
3. Digital Instruments, <http://www.di.com>.
4. Gacs, P. and Reif, J. H. A simple three-dimensional real-time reliable cellular array. Journal of Computer and System Sciences, Vol. 36, No. 2, pp. 125-147, April 1990.

5. Integrated DNA technologies, <http://www.idtdna.com>.
6. LaBean, T., Yan, H., Kopatsch, J., Liu, F., Winfree, E., Reif, J. H., and Seeman, N.C. The construction, analysis, ligation and self-assembly of DNA triple crossover complexes. *Journal of American Chemical Society*. 122, 1848-1860 (2000).
7. Liu, D., Wang, M., Deng, Z., Walulu, R., and Mao, C. Tensegrity: construction of rigid DNA triangles with flexible four-arm DNA junctions. *Journal of the American Chemical Society*, December 16, 2003.
8. Seeman, N.C. and Kallenbach, N.R. DNA branched junctions. *Annual Review of Biophysics and Biomolecular Structure*, Vol. 23, pp. 53-86, 1994.
9. Seeman, N. C. DNA in a material world. *Nature* 421, 427 – 431. January 23, 2003.
10. Seeman, N.C. In the nick of space: generalized nucleic acid complementarity and DNA nanotechnology, *Synlett*, No. X, pp. 1536-1548, 2000.
11. Seeman, N.C. DNA nicks and nodes and nanotechnology. *Nano Letters*, Vol. 1, No. 1, pp. 22-26, 2001.
12. Seeman, N.C. Nucleic acid nanostructures and topology. *Angewandte Chemie International Ed. English*. 37, 3220-3238 (1998)
13. Sha, R., Liu, F., and Seeman, N.C. Atomic force microscopic measurement of the interdomain angle in symmetric Holliday junctions. *Biochemistry*, Volume 41, pp. 5950-5955, (2002).
14. Simmel, F.C. and Yurke B. DNA machines for molecular self-assembly. *Nanotech 2001 Vol. 2. Technical Proceedings of the 2001 International Conference on Computational Nanoscience and Nanotechnology*, 2001.
15. Ted Pella, <http://www.tedpella.com>.
16. Wang, H. Dominoes and the AEA case of the decision problem. *Proceedings of the Symposium in the Mathematical Theory of Automata (Polytechnic Press, Brooklyn, NY)*, pp.23-55, 1963.
17. Winfree, E. PhD Thesis: Algorithmic self-assembly of DNA. California Institute of Technology, June 1998.
18. Winfree E., and Rothmund, P. Private communication.
19. Winfree, E., Sun, W., and Seeman, N.C. Design and self-assembly of two-dimensional DNA crystals. *Nature* 394, 539-544 (1998).
20. Yan, H., Feng, L., LaBean, T. H., and Reif, J. H. Parallel molecular computation of pairwise XOR using DNA string tile, Ninth International Meeting on DNA Based Computers (DNA9), Madison, Wisconsin, June 2-4, 2003.
21. Yan, H., Park, S.H., Finkelstein, G., Reif, J. H., and LaBean T. H. DNA-templated self-assembly of protein arrays and highly conductive nanowires, *Science*, Vol. 301, pp. 1882-1884 (2003).
22. Yang, X., Wenzler, Lisa., Qi, J., Li, X., and Seeman, N. Ligation of DNA triangles containing double crossover molecules. *Journal of the American Chemical Society* 120, pp. 9779-9786, 1998.