

CensorSpoofer: Asymmetric Communication using IP Spoofing for Censorship-Resistant Web Browsing

Qiyang Wang
Dept. of Computer Science,
UIUC
qwang26@illinois.edu

Xun Gong
Dept. of Electrical & Computer
Engineering, UIUC
xungong1@illinois.edu

Giang T. K. Nguyen
Dept. of Computer Science,
UIUC
nguyen59@illinois.edu

Amir Houmansadr
Dept. of Computer Science,
UT Austin
houmansadr@utexas.edu

Nikita Borisov
Dept. of Electrical & Computer
Engineering, UIUC
nikita@illinois.edu

ABSTRACT

A key challenge in censorship-resistant web browsing is being able to direct legitimate users to redirection proxies while preventing censors, posing as insiders, from discovering their addresses and blocking them. We propose a new framework for censorship-resistant web browsing called *CensorSpoofer* that addresses this challenge by exploiting the asymmetric nature of web browsing traffic and making use of IP spoofing. CensorSpoofer de-couples the upstream and downstream channels, using a low-bandwidth indirect channel for delivering upstream messages (URLs) and a high-bandwidth direct channel for downloading web content. The upstream channel hides the request contents using steganographic encoding within Email or instant messages, whereas the downstream channel uses IP address spoofing so that the real address of the proxy is not revealed either to legitimate users or censors. We built a proof-of-concept prototype that uses encrypted VoIP for this downstream channel and demonstrated the feasibility of using the CensorSpoofer framework in a realistic environment.

Categories and Subject Descriptors

C.2.1 [Computer-Communication Networks]: Network Architecture and Design—*Network communications*; C.2.0 [Computer-Communication Networks]: General—*Security and protection*

Keywords

Censorship resistance, asymmetric communication, IP spoofing, Voice-over-IP

1. INTRODUCTION

Today, the Internet is playing an ever-increasing role in social and political movements around the world. Activists

Permission to make digital or hard copies of all or part of this work for personal or classroom use is granted without fee provided that copies are not made or distributed for profit or commercial advantage and that copies bear this notice and the full citation on the first page. To copy otherwise, to republish, to post on servers or to redistribute to lists, requires prior specific permission and/or a fee.

CCS'12, October 16–18, 2012, Raleigh, North Carolina, USA.
Copyright 2012 ACM 978-1-4503-1651-4/12/10 ...\$10.00.

use it to coordinate their activities and to inform the general people of important information that is not available via traditional media channels. The role played by Twitter, Facebook, YouTube, CNN iReport and many other websites/blogs in the recent events in the Middle East is a great example of this [34, 47].

The free flow of information and exchange of ideas on the Internet have been perceived as a serious threat by repressive regimes. In response, they have imposed strong censorship on the Internet usage of their citizens. They monitor, filter, trace, and block data flows using sophisticated technologies, such as IP address blocking, DNS hijacking, and deep packet inspection [32, 50]. For example, the “Great Firewall of China” blocks almost all popular social networks, such as Facebook, Twitter and Flickr, and other websites that may provide political information contrary to the state’s agenda, such as Youtube, Wikipedia, BBC News, and CNN [60]. To exercise control over the Internet, the Chinese government employs an Internet police force of over 30 000 people to constantly monitor the citizens’ online activities [45], and an individual who is caught violating the laws of Chinese censorship is subject to payment of fines [24].

There are many tools that aim to circumvent such censorship [1, 2, 40, 48]; a typical approach is to deploy a redirection proxy that provides access to blocked sites. Censors are, however, eager to locate such proxies and block them as well; a particularly powerful approach is the *insider attack*, wherein censors pretend to be legitimate users of the service in order to locate and shut down the proxies. Limiting the amount of information each user gets and trying to identify compromised insiders can partially mitigate this attack [51, 52, 56]; however, these techniques are unlikely to survive a powerful adversary who can deploy a very large number of corrupt users. An alternate approach is to never reveal the proxies’ addresses to users and thus be completely immune to the insider attack. Some recent work suggests strategically placing special deflection routers at core Internet ISPs to transparently redirect users’ traffic to the proxies [44, 49, 59]. Such a deployment, however requires a significant resource investment that is likely to come only from a (pro-Internet freedom) government agency, as well as cooperation of large ISPs.

We propose a new approach, CensorSpoofer, that can be deployed using minimal resources, perhaps volunteered by ordinary people interested in promoting Internet freedom.

(The Tor project [40] has demonstrated the feasibility of building a successful service with contributions from such volunteers.) Our key insight is that it is possible to use IP address spoofing to send data from the proxy to a user without revealing its actual origin. Such a spoofed channel allows communication in a single direction only; however, we can exploit the asymmetric nature of web-browsing traffic, using a low-bandwidth indirect channel, such as steganographic instant messages or Email, to communicate requests from the user to the proxy. To avoid identification by the censor, CensorSpoofers mimics an encrypted VoIP session to tunnel the downstream data, since the VoIP protocol does not require endpoints to maintain close synchronization and does not reveal its contents to the censor. We also explore additional steps that need to be taken to prevent detection, namely, choosing a plausible fake IP source address.

To demonstrate the feasibility of CensorSpoofers, we built a proof-of-concept prototype implementation and tested it in a real-world environment. Our experiments show that our prototype can be successfully used for browsing the web while resisting blocking efforts of the censors.

The rest of this paper is organized as follows. We introduce the related work in Section 2. Section 3 presents the basic concepts, including the threat model and system goals. Section 4 describes the framework of CensorSpoofers. In Section 5, we elaborate a concrete design of CensorSpoofers based on VoIP, and analyze its security in Section 6. Section 7 presents our prototype implementation and the evaluation results. We conclude in Section 8.

2. RELATED WORK

In response to Internet censorship, many pragmatic systems such as Dynaweb/freemate [1], Ultrasurf [2], and Psiphon [48] have been developed to help people bypass censorship. All these systems are based on a simple idea: let the user connect to one of the proxies deployed outside the censor’s network, which can fetch blocked webpages for the user. To hide the nature of the traffic, the communications with the proxy are encrypted. Infranet [41] takes things a step further, embedding the real communication inside a cover web session, using covert channels to communicate the request and image steganography to return the data. However, while escaping detection by outsiders, these designs are vulnerable to the insider attack, where the censor pretends to be an ordinary user to locate the proxies and then block them.

Tor [40] also uses proxies (called *bridges*, run by volunteers) to resist censorship, but employs more advanced strategies to limit the distribution of proxies’ IP addresses. So far, Tor has tried four different distribution strategies. First, each user would receive a small subset of bridges based on his or her IP address as well as the current time. Second, a small subset of bridges could be obtained by sending a request via Gmail. These strategies fail to protect against an adversary who has access to a large number of IP addresses and Gmail accounts; Chinese censors were able to enumerate all bridges in under a month [3]. (McLachlan and Hopper further showed that open proxies could be used to gain access to a large number of IP addresses [53]). The third strategy involves distributing bridge addresses to a few trusted people in censored countries in an ad hoc manner, who then disseminate this information to their social networks. Fourth, an individual can deploy a private bridge and give the bridge’s address only to trusted contacts. These

methods can resist bridge discovery but reach only a limited fraction of the population of potential bridge users.

Several researchers have tried to design better proxy distribution strategies [42, 51, 52, 56] that aim to identify users who are likely to lead to a proxy being blocked using past history and directing new proxy information towards other users. However, these designs are not likely to withstand a censor who controls a large number of corrupt users.

TriangleBoy [4] is a circumvention system that is similar in spirit to Tor-bridge and also uses IP spoofing. In TriangleBoy, a user connects to one of the TriangleBoy proxies run by volunteers, and the proxy forwards the user’s URLs to a SafeWeb server, which fetches the web pages and sends them back to the user by spoofing the source IP address with the proxy’s IP. The only difference between Tor-bridge and TriangleBoy is that in Tor the downstream traffic takes the same route (through several relays) as the upstream traffic, while in TriangleBoy the server sends the downstream traffic to the user directly using IP spoofing to improve efficiency. Note that, in spite of using IP spoofing, the TriangleBoy proxies are still exposed to users, which raises the same problem to the insider attack as Tor bridges; whereas, CensorSpoofers adopts a different architecture by using IP spoofing to conceal the proxy’s IP address, and hence is immune to the insider attack.

Similar to CensorSpoofers, another school of prior research tries to fundamentally resist the insider attack, i.e., tolerating any fraction of corrupt users, by hiding the proxy’s IP from any user and therefore the censors. One way to achieve this is to utilize indirect channels, i.e., relaying the traffic sent to/by the proxy through one or more intermediate nodes. For example, MailMyWeb [5] and FOE [6] utilize Email as the indirect channel. For these systems, users are required to be able to access foreign servers that support encryption (e.g., Gmail), in order to avoid being detected by the censor. Nevertheless, considering the Chinese government once temporarily blocked Gmail [35], we can envision that the censor would again block the few special Email providers upon finding out they are popularly used to bypass censorship.

It is important to note that, while CensorSpoofers also employs an indirect channel, we only use it for sending users’ requests (e.g., URLs), which are usually very small (especially after encoding URLs into small numbers) and easy to hide into any indirect channel using steganography. This allows us to obviate the need for special servers (e.g., external Email providers supporting encryption) to provide a secured and high-bandwidth indirect channel, and users can even use the local Email and IM providers controlled by the censor to access our system. Consequently, the cost of blocking the upstream indirect channel of CensorSpoofers is significantly higher: the censor has to block all overseas indirect communication (e.g., overseas Email and IM).

More recently, researchers proposed several infrastructure-assisted circumvention systems, including Telex [59], Decoy routing [49], and Cirripede [44]. Although these systems can support low-latency communication and perfectly resist the insider attack, they require a significant investment of effort by large ISPs. By contrast, CensorSpoofers is an infrastructure-independent circumvention system, allowing individuals to deploy their own anti-censorship systems without requiring support from network infrastructure.

Instead of aiming to provide low-latency communication,

some anti-censorship systems are designed to achieve censorship-resistant content sharing and/or distribution. For example, some proposals leverage peer-to-peer (P2P) networks to provide privacy-preserving file sharing, e.g., Freenet [38], membership concealing overlay network [57], and darknet [7, 54]. Collage [36] let users stealthily exchange censored information with an external proxy via a website that can host user-generated content (e.g., Flickr) using steganography.

3. CONCEPT

3.1 Threat Model

We consider a state-level adversary (i.e., the censor), who controls the network infrastructure under its jurisdiction. The censor has sophisticated capabilities of IP filtering, deep packet inspection, and DNS hijacking, and can potentially monitor, block, alter, and inject traffic anywhere in its network. However, the censor is motivated to allow citizens to *normally* access basic Internet services, such as IM, Email and VoIP, as blocking such services would lead to economic losses and political pressure. More specifically, we assume the censor is unwilling to interfere with the Internet connections of a user, e.g., an ongoing VoIP conversation, unless it has evidence that a particular connection is being used for bypassing censorship.

Furthermore, we assume the censor generally allows people to use common encryption protocols to protect their online privacy, e.g., SRTP [28] or ZRTP [31] for secure VoIP communication.¹ Thus far, this assumption has held true for most existing cases of Internet censorship, and the use of encrypted protocols such as SSL/TLS have formed the foundation of most existing anti-censorship systems [1, 2, 5, 6, 40, 44, 48, 49, 59]. Once again, blocking encrypted traffic reduces the security of normal citizens using the Internet for personal or business reasons, and thus censors are motivated to allow such traffic through. There have been important exceptions to this, including Iran’s blocking of all encrypted traffic prior to the 33rd anniversary of the Islamic Revolution [33] and Egypt’s complete disconnection of the Internet in response to nationwide protests [39]. Such drastic censorship requires fundamentally different circumvention approaches that are out of scope of our work.

We assume the censor can utilize its governmental power to force local IM, Email, and VoIP providers to censor their users’ communication. We also assume that the censor can block *any* foreign Internet website or service, such as an Email or instant messaging provider, if it has reason to believe that it is being used to circumvent censorship. The censor can rent hosts outside of its own network, but otherwise has no power to monitor or control traffic outside its network. Finally, we assume that the censor has sufficient resources to launch successful insider attacks, and thus is aware of the same details of the circumvention system as are known to ordinary users.

Similar to many existing systems [36, 40, 41, 44, 49, 59], our approach requires that users run specialized circumvention software on their computers. We assume that users are able to obtain authentic copies of the software without alerting

the government to this fact through some form of out-of-band communication. (We acknowledge, however, that secure and reliable mechanisms for distributing such software are an important area of future research.)

3.2 System Goals

CensorSpoofer aims to achieve the following goals:

Unblockability: The censor should not be able to block CensorSpoofer without incurring unacceptable costs (e.g., having to block all oversea Email communication).

Unobservability: The censor should not be able to tell whether a user is using CensorSpoofer without incurring unacceptable costs.

Perfect resistance to insider attacks: The censor should not be able to break unblockability or unobservability of CensorSpoofer even if nearly all users are compromised.

Low latency: CensorSpoofer should be able to fetch and deliver the web pages for users with low latency. For clarity, CensorSpoofer does not aim to support highly interactive web applications, such as Javascript.

Deployability: CensorSpoofer should be deployable by people with limited resources, without requiring any support from network infrastructure.

4. CENSORSPOOFER FRAMEWORK

4.1 Overview

In censored countries, users cannot visit blocked websites directly and have to connect to some external proxies to access these websites. These proxies’ IP addresses are exposed to users who connect to them, and therefore can be easily blocked by the censor who colludes with corrupt users. A natural solution to this is to employ indirect channels to hide the proxy’s IP address. For example, MailMyWeb [5] and FOE [6] use Email as the indirect channel for which the intermediate nodes are Email servers.

To carry voluminous downstream traffic (e.g., web content), the indirect channel must have *high bandwidth*. This requirement excludes steganographic indirect channels, such as steganographic IM/Email. As a result, the circumvention system has to rely on an encrypted indirect channel so as to utilize full capacity of the indirect channel while ensuring unobservability of the transmission of censored data. This requires the intermediate nodes of the indirect channel to support encryption (e.g., TLS/SSL) and reside outside the censor’s network (to avoid eavesdropping by corrupt intermediate nodes). Currently, only a few Email providers (including Gmail, and Hotmail) can meet these requirements. However, due to their limited user base in the censored country, the censor could simply block them altogether, as witnessed by Gmail being blocked in China in 2011 [35].

Our insights. We notice that for web browsing, the upstream traffic (e.g., URLs) is much lighter-weight than the downstream traffic. If an indirect channel is only used to send upstream messages, high bandwidth is no longer required for the indirect channel. This allows us to use *any* indirect channel with steganography to transmit upstream data. Besides, by using steganography, users can even use local IM or Email providers that potentially collude with the censor to access our circumvention system without being detected. The elimination of requiring special servers to construct the indirect channel makes it substantially harder

¹Although much of VoIP traffic is currently unencrypted, the trend is towards more widespread use of secure VoIP protocols; for example, a number of VoIP software clients [8–14] and VoIP phones [15, 16] have encryption functionality.

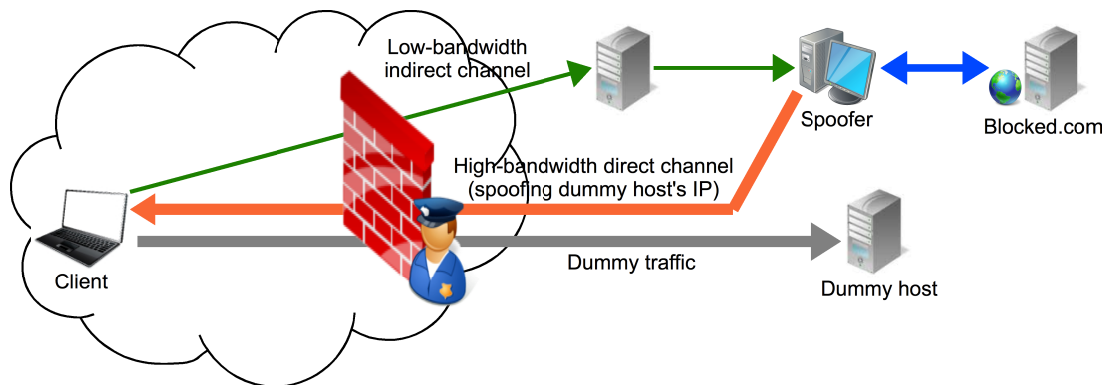

Figure 1: The CensorSpoofer framework. The user pretends to communicate with an external dummy host legitimately, and sends URLs to the spoofer via a low-bandwidth indirect channel (e.g., steganographic IM/Email). The spoofer fetches blocked webpages, and injects censored data into the downstream flow towards the user by spoofing the dummy host’s IP.

for the censor to block our circumvention system as all overseas Email and IM communication has to be prohibited.

As for the downstream channel, since the proxy’s IP (i.e., source IP) is not used in packet routing, we can adopt IP spoofing to conceal the proxy’s IP address. This eliminates the need for an indirect channel to hide the proxy’s IP, allowing us to use direct channels, which are more common and higher-bandwidth, to send voluminous downstream traffic.

Our design. Based on these insights, we design a new circumvention framework for web browsing, which uses asymmetric communication with separate upstream/downstream channels. In particular, a user who requires circumvention service first starts or pretends to start a legitimate communication session (e.g., a VoIP call) with a *dummy host* residing outside the censor’s network, and the proxy (called *spoofer*) injects censored data into the downstream flow towards the user by spoofing the dummy host’s IP, so that the censor believes the user is legitimately communicating with the dummy host *only*. It is important to note that the dummy host does not need to cooperate with the user or the spoofer, but it should look legitimate to the censor, e.g., its port for VoIP should “seem open” if the cover session is a VoIP call. Meanwhile, the user sends URLs to the spoofer through a low-bandwidth indirect channel, such as steganographic IM/Email. An illustration of the framework is provided in Figure 1.

Next, we discuss the downstream and upstream channels in more details.

4.2 Downstream Channel

1) To conceal the spoofer’s IP address, we apply IP spoofing in the downstream flow. Then, the first question is *what kind of traffic (TCP or UDP) is suitable for IP spoofing?*

Generally, hijacking TCP with IP spoofing is difficult. In TCP, end hosts maintain connection state and acknowledge received data. Suppose the client has established a TCP connection with the dummy host, and the spoofer knows the dummy host’s IP address and sequence number and tries to inject packets containing censored data into the downstream flow. First of all, the TCP connection with the dummy host must be kept alive; otherwise, the dummy host will send RST packets in response to the client’s packets, which can be easily detected by the censor. In addition, if the spoofer sends more data to the client than the dummy host (i.e., the sequence number of the spoofer is higher than that of

the dummy host), the censor can detect the inconsistency of the sequence numbers as long as the dummy host sends any packet to the client². Thus, the spoofer has to use the sequence numbers that have already been used by the dummy host (i.e., injecting packets as “resent packets”). However, in this case a censor with packet-recording capability can detect the injected packets by comparing the contents of packets with the same sequence number.

In contrast, UDP is a connectionless protocol and easier to hijack. Unlike TCP, end hosts of UDP do not maintain any connection state or acknowledge received data. Hence, if the dummy host keeps “quiet” and the client and the spoofer cooperate closely, it is feasible to deceive a smart censor into believing that the client is legitimately communicating with the dummy host over a duplex UDP channel. In this work, we focus on UDP traffic for IP spoofing. We present a concrete example of hijacking UDP in Section 5.

2) To ensure unobservability, the communication between the client and the spoofer (and the dummy host) should look like a normal UDP session of a legitimate Internet application. So, the second question is *what carrier applications should be used?*

UDP is mainly used for time-sensitive applications, such as VoIP, video conferencing, multi-player online games, webcam chat, online TV, etc. These applications usually have high-bandwidth channels. Other UDP applications, such as DNS and SNMP, have very limited bandwidth and thus are not suitable to carry voluminous downstream traffic.

We can further divide these applications into two classes based on their communication manner: (i) client-to-server communication, e.g., multi-players online games and online TV, and (ii) client-to-client communication, e.g., VoIP and video chat. To achieve better robustness to blocking, we prefer the applications in the second class, since for these applications the pool of dummy hosts is significantly larger (e.g., the dummy hosts could be any VoIP client on the Internet), making it much harder to block them altogether.

3) In CensorSpoofer, we use a dummy host as a cover to stealthily transmit censored data. The third question is *how to select plausible dummy hosts?*

²An active censor can check the dummy host’s current sequence number by replaying a client’s packet that is outside the dummy host’s receiving window; in this case the dummy host will reply an ACK packet containing its current sequence number.

The selection of dummy hosts is decided by the carrier application. For example, if the carrier application is VoIP, then each dummy host should be a potential VoIP client. Note that an active censor can use port scanning (e.g., using `nmap` [17]) to check if a dummy host is actually running the application, i.e., listening on a particular port (e.g., port 5060 for SIP-based VoIP). In response, we can use port scanning as well to obtain the list of dummy hosts. According to our experience, a dummy host is “quiet” (i.e., not sending any reply packet) to incoming UDP packets sent to a specific port, as long as this port is not “closed” on the dummy host. In many cases, port scanning is unable to determine whether a particular application is running on a target machine, since the target machine could be behind a firewall that is configured to filter probe packets. For example, `nmap` returns “open|filtered” or “closed|filtered” when it cannot tell whether the port is open/closed or the probe is filtered. This ambiguity plays in our favor as it makes a larger number of hosts appear to be plausible VoIP endpoints.

4) Finally, we note that not all Internet hosts can launch IP spoofing. Some ASes apply ingress and/or egress filtering to limit IP spoofing. The MIT ANA Spoofer project [18] has collected a wide range of IP spoofing test results, showing that over 400 ASes (22%) and 88.7M IPs (15.7%) can be used to launch IP spoofing. Therefore, we need to deploy our spoofer in the ASes where IP spoofing is not prohibited. We can utilize some tools, such as `nmap` and the spoofing tester developed by the Spoofer project [18], to test whether a host can perform IP spoofing.

4.3 Upstream Channel

To send upstream messages, each user uses a steganographic channel embedded in indirect communications such as IM and Email. Note that URLs are typically quite short and can be easily embedded into a small number of messages. Communication requirements can be further reduced by using a pre-agreed list of censored URLs and sending just the index of the desired site. Likewise, navigation within a site can use relative link numbering, requesting, e.g., the 3rd link from the front page of `www.cnn.com`. Note that steganography requires the use of a secret encoding key to remain invisible; this process can be made resilient to insider attacks by having each user register a separate pairwise key when joining the system. Specific steganographic constructions and their security are beyond the scope of this work. An important challenge that we must address, however, is the possibility that the censor will perform blocking based on the recipient’s IM identifier or Email address; we discuss a solution in Section 5.2.

5. A DESIGN OF CENSORSPOOFER

The CensorSpoofer framework can be instantiated using a number of protocol choices. In this section, we present a concrete design based on VoIP. We start with some background about VoIP systems.

5.1 Background of SIP-based VoIP

VoIP is an Internet service that transmits Voice over IP-based networks. It employs session control protocols, such as SIP, MGCP, and H.323, to setup and tear down calls. SIP is one of the most widely used VoIP signal protocols, because of its light weight. In this work, we focus on SIP-based VoIP systems.

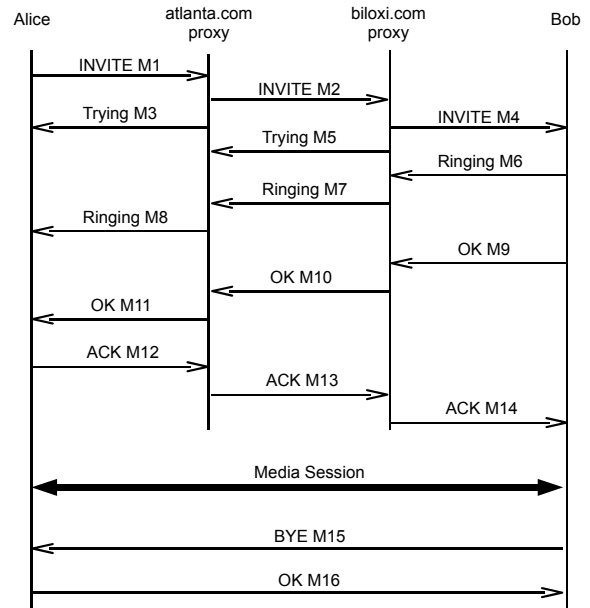

Figure 2: An example of a SIP session (registrars and location services are not shown).

SIP is an application layer protocol. It can run on either UDP or TCP. There are three main elements in SIP systems: user agents, location services, and servers.

- *User agents* are the end devices in a SIP network. They originate SIP requests to establish media session, and send and receive media. A user agent can be a physical SIP phone or SIP client software running on a computer (also called *softphone*). A user agent needs a SIP ID, which is signed up at a SIP provider, in order to make and receive SIP calls.
- *Location service* is a database that contains information about users, such as SIP IDs, the latest login IP addresses, preferences, etc. Location services generally do not interact directly with user agents.
- *Servers* are intermediary devices that are located within the SIP network and assist user agents in session establishment. There are two types of SIP servers: *registrar* and *proxy*. A registrar receives SIP registration requests and updates the user agent’s information (e.g., login IP address) into the location service. A SIP proxy receives SIP requests from a user agent or another proxy and forwards the request to another location.

Here is an example to show how a user (Alice) calls another user (Bob). Suppose Alice has signed up a SIP ID `alice@atlanta.com` at the SIP provider `atlanta.com`, and Bob got his SIP ID `bob@biloxi.com` from `biloxi.com`, and Alice knows Bob’s SIP ID. When Bob comes online, he first sends a registration request to the registrar of `biloxi.com` with its current IP address. So does Alice to register herself at the registrar of `atlanta.com`.

The SIP call initialization process is shown in Figure 2. First, Alice sends an INVITE message (M1), which contains her SIP ID and IP address, Bob’s SIP ID, her supported media codecs, etc., to the proxy of `atlanta.com` (note that at this point Alice does not know Bob’s IP address). The local proxy performs a DNS lookup to find the IP address of the proxy serving Bob’s domain, i.e., `biloxi.com`, and then

forwards the INVITE message (M2) to the remote proxy. At the meantime, the local proxy sends a Trying response (M3) back to Alice, indicating that the INVITE has been received and is being routed to the destination. Upon receiving the INVITE message, the proxy of `biloxi.com` sends a query to its location service to look up the registered IP address of Bob, and then it forwards the INVITE message (M4) to Bob. The user agent of Bob sends a Ringing response (M6) to the proxy indicating that Bob’s phone is ringed. If Bob decides to answer the phone, an OK message containing Bob’s current IP (M9) is sent towards Alice; otherwise, a Reject response is returned (not shown in the figure). From the received OK message, Alice learns Bob’s IP address, and sends an ACK message towards Bob (M12, M13, M14). At this point, the SIP initialization session is done, and Alice and Bob start the media session by sending each other audio data directly. At the end of the media session, either party can send a BYE message (M15) to close the call.

The media session uses Real-time Transport Protocol (RTP) to transmit audio data, and Real-time Transport Control Protocol (RTCP) to provide out-of-band statistic and control information for the RTP flow. Both RTP and RTCP run on top of UDP. VoIP clients can use SRTP/SRTCP [28]—an encrypted version of RTP/RTCP—to encrypt their voice communication. SRTP/SRTCP only requires the user to install a user agent that has encryption features, and does not require VoIP servers to support encryption. This implies that the user can use any VoIP provider, including local providers that collude with the censor, to access our circumvention system. The encryption key for SRTP/SRTCP can be either established beforehand, e.g., via MIKEY [25], or negotiated on the fly using ZRTP [31]. In this work, we consider using pre-established keys for SRTP/ SRTCP.

5.2 Censorship Circumvention

A sketch of the circumvention procedure is as follows. The client first initializes a SIP session with the spoofer by sending out a normal INVITE message. Upon receiving the INVITE message, the spoofer randomly selects a dummy host and replies with a manipulated OK message that looks like originating from the dummy host. When the OK message arrives, the client starts to send encrypted RTP/RTCP packets with random content to the dummy host, and the spoofer starts to send encrypted RTP/RTCP packets to the client by spoofing the dummy host’s IP address. Meanwhile, the client sends URLs through a steganographic IM/Email channel to the spoofer. The spoofer fetches the webpages, puts them into RTP packet payloads and sends them to the client. To terminate the circumvention session, the client sends a termination signal to the spoofer over the upstream channel, and then the spoofer sends a BYE message (with IP spoofing) to the client to close the call.

5.2.1 Invitation-based Bootstrapping

Since the censor can learn the callee’s SIP ID from the INVITE message, the user cannot call a common SIP ID, because otherwise he/she will be detected once the censor learns the spoofer’s SIP ID from corrupt users. There is a similar issue for the steganographic IM/Email channel: the censor can detect users sending IMs or Emails to the spoofer based on the recipient’s IM ID or Email address (generally referred to as *upstream ID*).

To address this, we let the spoofer use a *unique SIP ID*

and a *unique upstream ID* to communicate with each client. Hence, the SIP IDs and upstream IDs of the spoofer learned by corrupt users cannot be used to detect honest users. To avoid the bottleneck of having the spoofer create a large number of SIP and upstream IDs by itself, we let each client sign up a SIP ID and an upstream ID on behalf of the spoofer, and give them to the spoofer when joining the system. We achieve this by introducing an invitation-based bootstrapping process.

In particular, if a user Alice wants to join the circumvention system, she needs an invitation and help from an existing CensorSpoofer user (say Bob). Alice must trust Bob (e.g., Bob is a friend of Alice); otherwise, Bob could simply report Alice to the censor for attempting to access circumvention service. (We note that similar invitation-based bootstrapping strategies have already been adopted by some real-world circumvention systems, e.g., Psiphon [48].) First, Alice needs to sign up two SIP IDs and two upstream IDs. One pair of SIP ID and upstream ID is for herself, and can be obtained from her local SIP and IM/Email providers (which potentially collude with the censor). The other pair is for the spoofer, and must be signed up at abroad SIP and IM/Email providers (not necessarily supporting encryption). If all external SIP, IM, or Email providers are blocked by the censor, Alice can ask Bob to use his already-established circumvention channels to sign up these IDs for her. Then, Alice encrypts the following registration information with the spoofer’s public key:

```
caller's SIP ID | master secret |
callee's SIP ID | passwd for the callee's SIP ID |
upstream ID | passwd for the upstream ID
```

The master secret is used to derive SRTP/SRTCP session keys (and the key for the steganographic upstream channel if necessary), and the passwords are for the spoofer to login the callee’s SIP ID and the upstream ID.

To complete the bootstrapping, Alice needs to deliver the encrypted registration information to the spoofer. Alice could ask Bob to forward the whole registration information to the spoofer through his upstream channel. To reduce the bandwidth consumption of Bob’s upstream channel, Alice could let Bob only forward the encrypted upstream SIP ID and password to the spoofer; once her upstream channel is established, she can send the rest registration information to the spoofer by herself.

Note that our unique-ID assignment strategy cannot be applied to existing proxy-based circumvention systems, such as Tor, to improve the robustness against the insider attack. This is because the “ID” in CensorSpoofer is an application-level ID, and it is feasible to get a large number of them and use a unique one for each user; whereas, in Tor, the “ID” is the proxy’s IP address, and IP addresses are commonly viewed as a scarce resource and it is hard to get a large number of spare IP addresses.

For the spoofer, it needs to run multiple SIP IDs and multiple upstream IDs at the same time (possibly with a common service provider). In general, IM/Email servers and SIP registrars do not limit the number of accounts registered from a common IP address, because it is possible that multiple legitimate clients are behind a NAT. We did some tests on two real-world VoIP providers `ekiga.net` and `mixvoip.com` with 100 different SIP IDs running on one of our lab machines, respectively. It turned out for both

providers, all these SIP IDs can be registered and receive calls successfully. We also did tests on Gtalk with 10 different accounts on the same machine and all of them worked properly.

5.2.2 Manipulating the OK Message

Once the bootstrapping is done, the client can initialize a circumvention session by calling the SIP ID that was given to the spoofer at the registration. In the SIP protocol, the callee’s IP address is written into the OK message (more specifically, the enclosed SDP message [27]), and later is used by the caller to send RTP/RTCP packets to the callee. Since the OK message can be eavesdropped by the censor, the spoofer cannot put its real IP into the OK message.

For this, we use a trick to hide the spoofer’s IP address. According to the IETF standards [27, 29], the SDP messages are not checked by SIP proxies. This means the spoofer can put the dummy host’s IP, instead of its own IP, into the OK message, without influencing the OK message being forwarded back to the client. Since the registered IP of the callee (kept by the location service of the spoofer’s VoIP provider) is unknown to the censor, the manipulated OK message is still plausible to the censor. To verify the feasibility of replacing the spoofer’s IP address in the OK message in practice, we utilized `netfilter_queue` [19] to modify the OK message on the fly, and tested it with two VoIP providers `ekiga.net` and `mixvoip.com` and an unmodified VoIP softphone PJSUA [11]. We found all manipulated OK messages were successfully delivered to the client and the client-side softphone started to send RTP/RTCP packets to the replaced IP address after receiving the OK message.

5.2.3 Selection of Dummy Hosts

A SIP client listens on TCP and/or UDP port 5060 for SIP signaling, and the ports for RTP/RTCP are selected randomly on the fly (usually RTP uses an even port and RTCP uses the next higher odd port). To check the legitimacy of a dummy host, the censor could apply port scanning to test if the ports used by VoIP are open on the dummy host. In response, we can also use port scanning to get the list of dummy hosts. As we mentioned before, in many cases, port scanning can only return an ambiguous result. For `nmap` [17] (the state-of-the-art port scanning tool), the possible probing results include “open”, “closed”, “filtered”, “unfiltered”, “open|filtered”, “closed|filtered”, and “host seems down”. Only “closed” can clearly tell the censor that a particular application is not running on the target machine. When the status is “host seems down”, it is very likely that the target host is offline. For safety, we also exclude “host seems down” from the acceptable probing states. Therefore, we let the spoofer periodically run port scanning with randomly selected IPs outside the censor’s network to get a list of acceptable $\langle ip, rtp_port \rangle$ (see Algorithm 1).

Another strategy for the censor to check legitimacy of the dummy host is to compute the predicted AS path of the downstream traffic (supposedly from the dummy host) and compare it against the observed entry point (into the censor’s network) of the spoofing traffic sent by the spoofer. If the dummy host is located far from the spoofer, it is likely that the entry point of the spoofing traffic is inconsistent with its claimed AS path. To deal with this, we first use `traceroute` to compute the actual AS path from the spoofer to the client (called *reference AS path*), and then choose a

Input: IP_range // outside censored networks
Output: dum_hosts
 $dum_hosts \leftarrow \{\}$;
 $unaccepted \leftarrow \{closed, host_seems_down\}$;
foreach $ip \in IP_range$ **do**
 if $port_scan(ip, sip_port) \notin unaccepted$ **then**
 $rtp_port \leftarrow rand_even_port()$;
 $rtcp_port \leftarrow rtp_port + 1$;
 if $port_scan(ip, rtp_port) \notin unaccepted$ **and**
 $port_scan(ip, rtcp_port) \notin unaccepted$ **then**
 add $\langle ip, rtp_port \rangle$ to dum_hosts ;
 end
 end
end

Algorithm 1: Port scanning algorithm to find a list of candidate dummy hosts

dummy host whose predicted AS path to the client is consistent with the reference AS path with respect to their entry points. Researchers have proposed several AS-path inference algorithms with high predication accuracy (such as [55]).

In addition, since the port status on a probed host may change over time, we let the spoofer keep track of the previously found dummy hosts and maintain a list of alive dummy hosts. When a circumvention request arrives, the spoofer picks a dummy host from the alive-host list, and keeps checking the VoIP ports of this dummy host during the circumvention session. If the spoofer detects any port of SIP, RTP and RTCP on the dummy host is closed before the circumvention session ends, it sends a BYE message to the client immediately to terminate the SIP session. If the client wants to presume the circumvention session, it needs to initialize another SIP session with the spoofer.

5.2.4 Traffic Pattern and Bandwidth

To resist traffic-pattern-analysis attack, the client and the spoofer should follow certain patterns of legitimate VoIP traffic when sending RTP/RTCP packets. For VoIP, both RTP and RTCP packets are of the same size and sent periodically³. The packet size and sending frequency are defined by the audio codec, which is negotiated during the SIP initialization session. The codec determines the bandwidth of the downstream channel ($\sim pkt_size \times freq$). Some codecs that are used to achieve better voice quality can provide higher bandwidth (e.g., 64 Kbps with G.711), while others provide lower bandwidth (e.g., 16 Kbps with iLBC). Note that the same bandwidth is consumed at the dummy host, due to the dummy traffic sent by the client. We can use some bandwidth estimation tools (e.g., `packet-trains` [46]) to figure out how much available bandwidth the dummy host has, and based on that, we choose an appropriate codec to avoid consuming too much bandwidth of the dummy host.

5.2.5 Packet Loss

UDP does not provide reliable transmission. A RTP packet containing data of a blocked webpage could be lost during transmission, causing failure of reconstructing the webpage at the client. To tolerate packet loss, we use Forward Er-

³Some softphones have the option of Voice Activity Detection (VAD), which avoids unnecessary coding and transmission of silence voice data. With VAD, the RTP packet size and sending interval may vary. In this work, we assume no VAD is used at the spoofer or the client for simplicity.

ror Correction (FEC) codes (e.g., Reed-Solomon code [26]) inside the downstream channel, so that the client can recover the webpage as long as a certain number of packets are received.

6. SECURITY ANALYSIS

We next discuss the security properties of CensorSpoofers against potential passive and active attacks.

6.1 Geolocation Analysis

Since the callee's SIP ID and IP address contained in the OK message are transmitted in plaintext, a sophisticated censor could record all the IP addresses that have been bound to a particular SIP ID over time, and try to discover abnormality based on the geolocations of these IPs. For instance, a SIP ID would look suspicious if its registered IPs for two closely conducted SIP sessions are geographically far from each other (e.g., the SIP ID is first registered with an IP in U.S. and 1 hour later it is registered again with another IP in Europe).

To deal with this, instead of picking dummy hosts randomly, the spoofer can choose a set of dummy hosts that are geographically close, for a particular SIP ID, according to an IP-geolocation database (such as [20]). When a SIP ID is used by the spoofer for the first time, the spoofer randomly selects a *primary dummy host* for it, and keeps this information in the user database. For subsequent SIP sessions calling this SIP ID, the spoofer preferentially assigns its primary dummy host for it. If the port status of the primary dummy host becomes "closed", the spoofer then preferentially chooses a dummy host from those that have been assigned to this SIP ID (which are also stored in the user database). If none of them is available, the spoofer selects a new dummy host that is geographically close to the primary dummy host for this SIP ID. (Note that the spoofer should make sure that a particular dummy host is not being used by two or more SIP IDs at the same time.)

Furthermore, each user can create multiple SIP IDs. When a circumvention session is carried out very close to the previous one, or when the spoofer cannot find a suitable dummy host for a SIP ID, the user can call another SIP ID instead.

6.2 User Agent & Operating System (OS) Fingerprinting

The SIP protocol defines the basic formats of SIP messages, but allows user agents (i.e., softphones or SIP phones) to add optional information to the SIP messages, such as the user's display name, timestamps, and the software/hardware information of the user agent. In addition, SIP messages (e.g., INVITE and OK) contain some random identifiers, such as "To tag" and "From tag", which are generated by the user agent with self-defined length. Additionally, the SIP messages also contain the codecs that are supported by the user agent.

The above information allows a sophisticated censor to fingerprint a particular user agent. As a result, the censor may detect users communicating with the spoofer based on the user-agent fingerprint of the spoofer. To address this, the spoofer can create a number of user-agent profiles based on the popular SIP phones and softphones, and assign one of them to each SIP ID. For a SIP session calling a particular SIP ID, the spoofer generates corresponding SIP messages based on the user-agent profile of the SIP ID.

In addition, some softphones are only available for certain OSes. For example, SFLphone [9] can only be used on Linux, and Blink [8] is only available for Windows and Mac users. Hence, a sophisticated censor can use OS fingerprinting tools (e.g., the OS detection of `nmap` [17]) to check if the dummy host's OS is consistent with its user agent (learnt from the user-agent fingerprint). To handle this, the spoofer can also use the OS fingerprinting tool to detect the dummy host's OS and assign an appropriate user-agent profile.

6.3 Traffic Manipulation

The censor can also try to manipulate traffic flows in order to detect users accessing our circumvention system.

In anonymous communication systems (e.g., Tor [40]), an attacker could use traffic analysis to detect if two relays are on the same path of a flow, by injecting a specific traffic pattern at one relay (e.g., by delaying certain packets) and detecting the same pattern at the other relay [58]. If applying the same attacking methodology to CensorSpoofers, the censor could delay the packets sent by the user, and detect if there are any traffic pattern changes in the downstream flow. However, this attack is based on the precondition that the flows sent and received by the remote host are correlated, and this is not true for VoIP, since each VoIP client sends RTP/RTCP packets periodically, independent of the incoming flow.

Another way to manipulate traffic is to drop packets. Since the spoofer does not actually receive any RTP/RTCP packets from the user, the censor can drop the user's packets without even being noticed by either the spoofer or the user. The VoIP phones can tolerate a small number of random packet loss; but if there are no RTP/RTCP packets received for a certain period of time (e.g., 30 seconds), they will drop the call automatically. Hence, a censor can adopt the following strategy to detect a CensorSpoofers user: it blocks all the RTP/RTCP packets sent to the callee, and checks if the callee still sends packets to the client after a certain period of time (e.g., 30 seconds). However, the price of mounting this attack is very high. Since the censor is unable to tell which flow carries censored data, it has to drop all VoIP flows unselectively, causing normal VoIP conversations being interrupted.

The censor can also alter, reorder, inject or replay RTP/RTCP packets sent to the callee (i.e., the dummy host). However, since a normal VoIP client running the SRTP protocol can simply filter the invalid packets, such attacks cannot help the censor detect if the callee is a real SIP client or a dummy host.

6.4 SIP Message Manipulation

The censor can attempt to manipulate SIP messages. For instance, the censor can manipulate the IP of the callee (i.e., the dummy host) in the OK message, and check if there are any RTP/RTCP packets sent to the user. (Similar to the packet-dropping attack, this attack will make legitimate users unable to make and receive VoIP calls.) To resist this attack, the spoofer can compute a short keyed hash of the dummy host's IP (and other important data if any) using the SRTP session key, and put the hash value into some random identifiers (e.g., "To Tag") in the OK message. The user who knows the session key can use the embedded hash to verify the integrity of the dummy host's IP. If the user

Table 1: Bandwidths for different VoIP codecs

Codec	BW of downstream channel (Kbps)	Consumed BW of dummy host (Kbps)
G.711	64	87.2
G.722-64	64	87.2
G.726-40	40	54.7
iLBC	15.6	26.6

detects the OK message is manipulated, he will abandon the SIP session by not sending an ACK response.

7. PROTOTYPE AND EVALUATION

In this section, we report the evaluation results. Refer to Appendix for details of our prototype implementation.

7.1 Sketch of Prototype Implementation

The spoofer prototype has four components: a SIP message handler, a RTP/RTCP transmitter, an upstream message receiver, and a prefetching proxy. For the SIP message handler, we used `tcpdump` to create user-agent profiles, and `netfilter_queue` [19] to capture incoming INVITE messages. We used UDP raw sockets to send RTP/RTCP packets. The raw socket allows us to put an arbitrary IP into the source IP field in the IP header. We implemented a XOR-based encoder/decoder to handle packet loss. For this prototype, we used Gtalk as the upstream channel, although our system in no way depends on encrypted indirect channels like Gtalk. We implemented a simple Gtalk client using a python API `xmpppy` [21]. For ordinary web browsing, a user’s web browser sends separate HTTP requests for the html file of the webpage as well as the objects embedded in the webpage. To minimize the number of messages sent through the upstream channel, we implemented a prefetching proxy for the spoofer, which can parse the html file to figure out the missing objects and fetch these objects on behalf of the client, so that the client only needs to send a single HTTP request to the spoofer. Our implementation of the prefetching proxy is based on an open-source layout engine `QtWebKit` [22].

For the client, we implemented a client-side HTTP proxy to handle HTTP requests made by the user’s browser and HTTP responses received from the RTP channel. The proxy only forwards the first HTTP request to the spoofer via the Gtalk channel. We implemented a minimal browser application – simply a wrapper around `QtWebPage` – to load the webpages and provide statistic information for evaluation.

7.2 Evaluation

7.2.1 Performance Evaluation

The spoofer was deployed on an `Emulab` machine (located in Utah, U.S.), which has 3.0 GHz 64-bit Dual Core CPU with 1 GB cache and 2 GB of RAM and runs Ubuntu 11.04. We deployed 8 clients on `Planetlab`, which are all located in China, and the dummy hosts are located in Illinois, U.S.

To handle packet loss, we made the spoofer add a redundant XOR packet for every 10 packets. We chose the most commonly used VoIP codecs G.726-40, G.722-64, G.711, and iLBC, and set the corresponding RTP packet size and sending interval according to the standard specifications in [37]. The bandwidth provided by each codec and the consumed bandwidth of the dummy host are provided in Table 1.

Each client was configured to repeatedly download the

page of `wikipedia.org` (which is about 160 KB) for 20 times. For each download, we measured the time to download only the html file and the entire page, respectively. (Note that once the html file is downloaded, the user’s web browser will display the basic frame and the text of the webpage, and the user can start reading the text-based content.) We found that the clients were able to successfully download the page of `wikipedia.org` (which was blocked in China) using `CensorSpoofer`. The results of downloading times are provided in Figure 3a, 3b. We can see that with the codec G.711 or G.722-64, the downloading time for the whole page was 27 seconds, but it only took 6 seconds to load the html file.

In addition, we compared `CensorSpoofer` with existing circumvention systems. We installed a Tor client on one of the `Planetlab` machines, and made it connect to a bridge in the U.S. to download the webpage of `wikipedia.org` for 50 times. Additionally, we ran the same experiment by making the client connect to a public proxy of `NetShade`⁴ (a proxy-based circumvention & anonymity system), which is located in U.S. Figure 3c, 3d show that it did take longer time for `CensorSpoofer` to download the pages than the other two circumvention systems, because `CensorSpoofer` needs to reshape the downstream traffic into low-bandwidth VoIP traffic. However, its downloading time for small web contents, such as html files, is still acceptable.

We note that the performance of `CensorSpoofer` can be improved by fixing some limitations of our current implementation. For example, our current prototype of the spoofer does not start sending any packet to the client until it has received the entire response. We believe removing these limitations can reduce the downloading time.

We also notice that the main performance bottleneck of `CensorSpoofer` is the RTP channel that carries the voice data. We believe by using a higher-bandwidth downstream channel, such as video streaming, the performance of `CensorSpoofer` can be much improved.

7.2.2 Measurement of Dummy-Host Selection

To evaluate the easiness of finding dummy hosts, we implemented the port scanning algorithm (i.e., Algorithm 1 in Section 5.2.3) using `nmap` [17]. We considered China as the censored country. We randomly selected 10000 IPs (outside China) from the entire IP space, according to an IP-geolocation database [20]. We found 1213 IPs (12.1%) that meet our requirements; this indicates that there are a potentially large number of usable dummy hosts on the Internet.

Furthermore, we computed the percentage of appropriate dummy hosts for a specific client based on their predicted AS paths to the client. We implemented a widely used AS path inference algorithm [55] that is based on AS relationships [43]. We considered the top four ASes in China in terms of the number of covered direct IPs (according to [30]), and selected a random IP (i.e., the client) from each of the ASes. We randomly picked 225 dummy hosts out of the 1213 candidate dummy hosts, and computed the AS paths between them and the four clients. Then, we compared the output paths with the AS paths from the spoofer to the clients (computed using `traceroute`), and filtered the dummy hosts with inconsistent entry points. The results are shown in Table 2. We can see that for a specific client, there are enough dummy hosts to use, especially for the clients located in large ASes.

⁴<http://www.raynersoftware.com/netshade/>

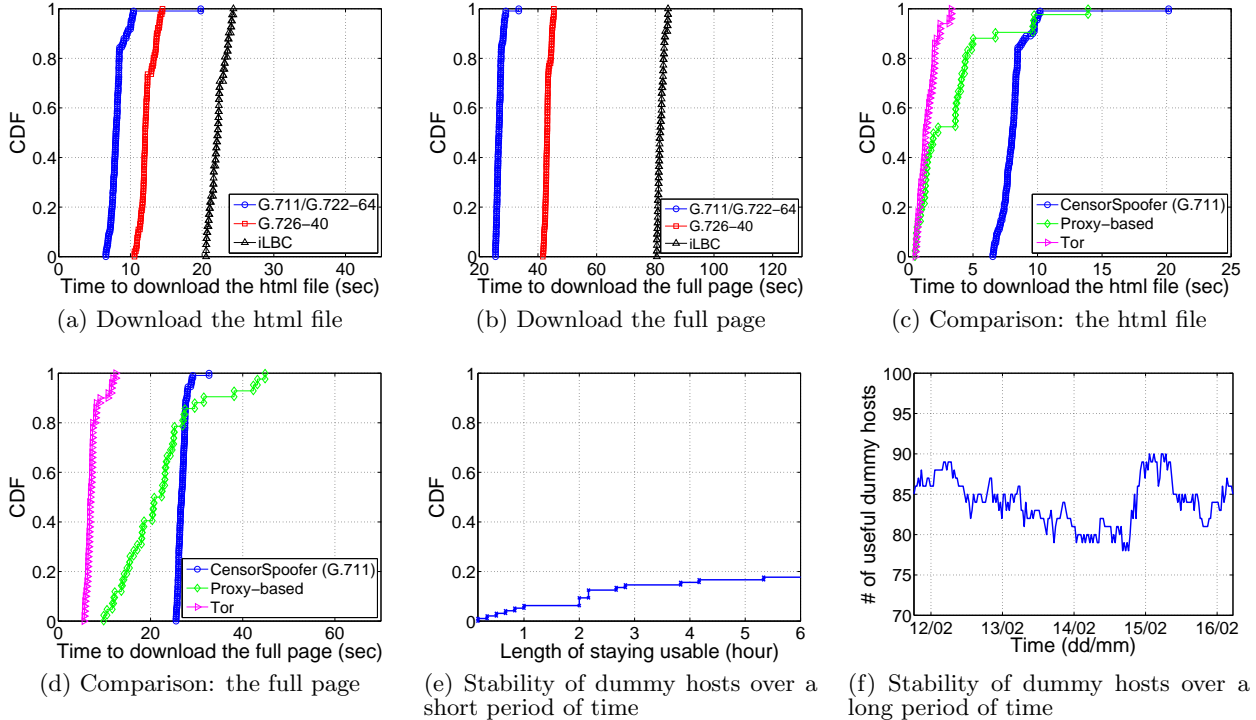

Figure 3: Evaluation (note that for (e) the CDF plot is truncated to `max_len_stay_usable = 6` hours, since many dummy hosts stay usable for a very long time)

Table 2: Usable dummy hosts based on AS paths (Spoofed-ASN = 38)

DST-ASN	% of direct IPs	Entry-ASN	# of usable dummy hosts	% of usable dummy hosts
4134	39.4%	4134	225	100%
4837	19.8%	4839	225	100%
9394	8.3%	9394	217	96.4%
4538	7.1%	23911	41	18.2%

In addition, we measured the stability of dummy hosts over time. Ideally, the dummy host should stay “usable” (i.e., none of its VoIP ports becomes “closed” or “host seems down”) during the circumvention session, so that the user does not need to re-initialize the SIP session to change dummy hosts. To justify this, we randomly selected 100 dummy hosts out of the 1213 candidate dummy hosts, kept sending RTP packets to each of them and checking the states of their VoIP ports. Figure 3e depicts the CDF of length of period for a dummy host to stay usable. We can see that over 90% dummy hosts can stay usable for more than 2 hours, and over 80% can stay usable for over 6 hours. This means in most cases, the users only need to establish one SIP session throughout their web browsing.

We also measured the stability of dummy hosts over a longer period of time. We kept track of the states of 100 randomly selected dummy hosts from Feb. 9th 2012 to Feb. 16th 2012. To simulate the practical scenario when the dummy hosts are used by our system to absorb VoIP traffic, we kept sending RTP packets to each dummy host periodically, with 1-hour sending period and 1-hour sleeping period. Figure 3f depicts the number of usable dummy hosts in that period. We can see that the total number of dummy hosts is almost stable, indicating that the pool of candidate dummy nodes does not shrink over time.

8. CONCLUSION

We proposed a new circumvention framework, CensorSpoofer, by exploiting the asymmetric nature of web browsing. CensorSpoofer decouples the upstream and downstream channels, using a low-bandwidth indirect channel for delivering URLs and a high-bandwidth direct channel for downloading web content. The upstream channel hides the requests using steganography within Email/IM; whereas the downstream channel uses IP spoofing to conceal the proxy’s real address. Unlike some existing circumvention systems, CensorSpoofer does not require any additional support from network infrastructure. We implemented a proof-of-concept prototype for CensorSpoofer, and the experimental results showed that CensorSpoofer has reasonable performance for real-world deployment.

9. ACKNOWLEDGEMENTS

We are grateful to Joshua Juen for his help with the AS path prediction. We thank Shuo Tang for helpful discussion on implementing the prefetching proxy. We also thank Prateek Mittal, Anupam Das, Sonia Jahid, and Joshua Juen for inspiring discussion at the beginning of this work. This work was supported in part by NSF CNS 09-53655 and the Boeing Trusted Software Center at the Information Trust Institute, University of Illinois.

10. REFERENCES

- [1] Dynaweb. http://www.dongtaiwang.com/home_en.php.
- [2] Ultrasurf. <http://www.ultrareach.com>.
- [3] Ten ways to discover Tor bridges. <https://blog.torproject.org/blog/research-problems-ten-ways-discover-tor-bridges>.
- [4] TriangleBoy Whitepaper. http://www.webrant.com/safeweb_site/html/www/tboy_whitepaper.html.
- [5] MailMyWeb. <http://www.mailmyweb.com/>.
- [6] Feed Over Email (F.O.E). <http://code.google.com/p/foe-project/>.
- [7] WASTE. <http://waste.sourceforge.net/>.
- [8] Blink. <http://icanblink.com/>.
- [9] SFLphone. <http://sflphone.org/>.
- [10] Zfone. <http://zfoneproject.com/>.
- [11] pjsua. <http://www.pjsip.org/>.
- [12] PhonerLite. http://www.phonerlite.de/index_en.htm.
- [13] Microsoft Lync. <http://technet.microsoft.com/en-us/library/gg195673.aspx>.
- [14] CounterPath. <http://www.counterpath.com/softphone-products.html>.
- [15] Cisco IP phones. http://www.cisco.com/en/US/docs/voice_ip_comm/cucm/security/4_0_1/secuview.html.
- [16] Grandstream. <http://www.grandstream.com/products/ip-voice-telephony/enterprise-ip-phones/gxp1100>.
- [17] nmap. <http://nmap.org/>.
- [18] The MIT ANA Spoofer project. <http://spoofer.csail.mit.edu/>.
- [19] netfilter-queue. http://www.netfilter.org/projects/libnetfilter_queue/.
- [20] IP geolocation database. <http://ipinfodb.com/>.
- [21] XMPPPY. <http://xmpppy.sourceforge.net/>.
- [22] QtWebKit. <http://trac.webkit.org/wiki/QtWebKit>.
- [23] OpenSSL. www.openssl.org.
- [24] How censorship works in china: A brief overview. http://www.hrw.org/reports/2006/china0806/3.htm#_Toc142395821.
- [25] Mikey: Multimedia internet keying. <http://www.ietf.org/rfc/rfc3830.txt>.
- [26] Reed-solomon forward error correction (fec) schemes. <http://www.ietf.org/rfc/rfc5510.txt>.
- [27] Sdp: Session description protocol. <http://www.ietf.org/rfc/rfc4566.txt>.
- [28] The secure real-time transport protocol (srtp). <http://www.ietf.org/rfc/rfc3711.txt>.
- [29] Sip: Session initiation protocol. <http://www.ietf.org/rfc/rfc3261.txt>.
- [30] Top 50 autonomous systems. http://cyber.law.harvard.edu/netmaps/country_detail.php?cc=CN.
- [31] Zrtp: Media path key agreement for unicast secure rtp. <http://www.ietf.org/rfc/rfc6189.txt>.
- [32] Defeat Internet Censorship: Overview of Advanced Technologies and Products, Nov. 2007. http://www.internetfreedom.org/archive/Defeat_Internet_Censorship_White_Paper.pdf.
- [33] Iran reportedly blocking encrypted internet traffic, 2012. <http://arstechnica.com/tech-policy/news/2012/02/iran-reportedly-blocking-encrypted-internet-traffic.ars>.
- [34] New blocking activity from iran, June, 16, 2011. <https://blog.torproject.org/blog/new-blocking-activity-iran>.
- [35] D. Barboza and C. C. Miller. Google accuses chinese of blocking gmail service. http://www.nytimes.com/2011/03/21/technology/21google.html?_r=2.
- [36] S. Burnett, N. Feamster, and S. Vempal. Chipping away at censorship with user-generated content. In *USENIX Security*, 2010.
- [37] Cisco. Voice over ip – per call bandwidth consumption. http://www.cisco.com/application/pdf/paws/7934/bwidth_consume.pdf.
- [38] I. Clarke, T. W. Hong, S. G. Miller, O. Sandberg, and B. Wiley. Protecting Free Expression Online with {Freenet}. *IEEE Internet Computing*, 6(1):40–49, 2002.
- [39] J. Cowie. Egypt leaves the internet, Jan. 2011. <http://www.renesys.com/blog/2011/01/egypt-leaves-the-internet.shtml>.
- [40] R. Dingleline, N. Mathewson, and P. Syverson. Tor: The second-generation onion router. In *USENIX Security Symposium*, August 2004.
- [41] N. Feamster, M. Balazinska, G. Harfst, H. Balakrishnan, and D. Karger. Infranet: Circumventing Web Censorship and Surveillance. In *USENIX Security*, Aug. 2002.
- [42] N. Feamster, M. Balazinska, W. Wang, H. Balakrishnan, and D. Karger. Thwarting web censorship with untrusted messenger discovery. In *Privacy Enhancing Technologies (PETS)*, 2003.
- [43] L. Gao. On inferring autonomous system relationships in the internet. *IEEE/ACM Trans. Netw.*, 9:733–745, December 2001.
- [44] A. Houmansadr, G. T. K. Nguyen, M. Caesar, and N. Borisov. Cirripede : Circumvention infrastructure using router redirection with plausible deniability categories and subject descriptors. In *ACM CCS'11*, 2011.
- [45] J. Jacob. How internet censorship works in china, 2011. <http://www.ibtimes.com/articles/113590/20110217/>.
- [46] R. Jain, S. Member, Shawn, and A. Routhier. Packet trains – measurements and a new model for computer network traffic. *IEEE Journal on Selected Areas in Communications*, 4:986–995, 1986.
- [47] J. Jarvis. Facebook, twitter, and the egyptian revolution, Feb. 13. 2011. <http://thefastertimes.com/mediaandtech/2011/02/13/facebook-twitter-and-the-egyptian-revolution/>.
- [48] J. Jia and P. Smith. Psiphon: Analysis and Estimation, 2004. http://www.cdf.toronto.edu/~csc494h/reports/2004-fall/psiphon_ae.html.
- [49] J. Karlin, D. Ellard, A. W. Jackson, C. E. Jones, G. Lauer, D. P. Mankins, and W. T. Strayer. Decoy Routing : Toward Unblockable Internet Communication. In *USENIX FOCI*, 2011.
- [50] C. S. Leberknight, M. Chiang, H. V. Poor, and F. Wong. A taxonomy of Internet censorship and anti-censorship. <http://www.princeton.edu/~chiangm/anticensorship.pdf>.
- [51] M. Mahdian. Fighting censorship with algorithms. In *Proceedings of FUN 2010*, 2010.
- [52] D. McCoy, J. A. Morales, and K. Levchenko. Proximax: A measurement based system for proxies dissemination. In *Financial Cryptography and Data Security (FC'11)*, 2011.
- [53] J. McLachlan and N. Hopper. On the risks of serving whenever you surf: Vulnerability of tor's blocking resistance design. In *WPES'09*, 2009.
- [54] B. Popescu, B. Crispo, and A. S. Tanenbaum. Safe and private data sharing with turtle: Friends team-up and beat the system. In *The 12th Cambridge International Workshop on Security Protocols*, April 2004.
- [55] J. Qiu and L. Gao. Cam04-4: As path inference by exploiting known as paths. In *GLOBECOM '06*, 2006.
- [56] Y. Sovran, A. Libonati, and J. Li. Pass it on: Social networks stymie censors. In *IPTPS'08*, Feb 2008.
- [57] E. Y. Vasserman, R. Jansen, J. Tyra, N. Hopper, and Y. Kim. Membership-concealing overlay networks. In *ACM CCS'09*, Nov. 2009.
- [58] X. Wang, S. Chen, and S. Jajodia. Network flow watermarking attack on low-latency anonymous communication systems. In *IEEE Oakland*, 2007.
- [59] E. Wustrow, S. Wolchok, I. Goldberg, and J. A. Halderman. Telex: Anticensorship in the Network Infrastructure. In *20th USENIX Security Symposium*, Aug. 2011.
- [60] J. Zittrain and B. Edelman. Internet Filtering in China. *IEEE Internet Computing*, 7(2):70–77, 2003.

APPENDIX

A. THE SPOOFER PROTOTYPE

SIP Message Handler. We use PJSUA v1.12 [11] as an out-of-box tool to register callees’ SIP IDs. We choose PJSUA because we can easily register multiple SIP IDs using the `-config-file` option. To prevent the user-agent fingerprinting attack, we use `tcpdump` to pre-record the OK messages generated by different softphones, and use them as templates to generate corresponding OK messages.

When starting the spoofer, the SIP message handler first launches PJSUA to register callees’ SIP IDs, so that the SIP proxies can forward INVITE messages related with these SIP IDs to the spoofer. We use `netfilter_queue` [19] to capture incoming INVITE messages. (Since PJSUA requires to bind port 5060, we do not create a socket bound to port 5060 to receive INVITE messages.) For each INVITE message, the handler replies with an OK message that is crafted according to the content the INVITE message, and creates a thread for the RTP/RTCP transmitter for this client.

RTP/RTCP Transmitter. The RTP/RTCP transmitter needs to send RTP/RTCP packets periodically with IP spoofing. For this, we use a UDP raw socket, which allows us to put an arbitrary IP into the source IP field in the IP header. To encrypt RTP/RTCP packets, we use AES-128 of OpenSSL v1.0.0 [23] with a pre-shared key. Since the sending frequency of RTCP packets is much lower than that of RTP packets, we only use RTP to send censored data.

To handle packet loss, we implemented a simple XOR-based encoder/decoder. The RTP/RTCP transmitter partitions the flow of each task (i.e., downloading a particular webpage) into fixed-sized data blocks, and multiplex the blocks of different tasks of the same client into one stream, which is further divided into groups of size λ (e.g., $\lambda = 10$ blocks). For each group, the transmitter generates a redundant block by XORing all λ blocks in the group, so that any λ out of the $\lambda + 1$ blocks are sufficient to recover the whole group. Whenever a RTP packet needs to be sent, the transmitter checks if there are any available blocks (including XOR blocks) in the buffer for this client. If so, it writes one block into the RTP payload and sends it out; otherwise, the RTP packet is stuffed with random data.

Note that some blocks may contain data less than their capacity (e.g., the last block of a task), and blocks may arrive at the client in different order than being sent out; besides, the client should be able to differentiate blocks for different tasks. To handle these, we use the first 4 bytes of the RTP payload to embed a block sequence number (2 bytes), a task number (1 byte), and block size (1 byte). These fields are encrypted together with the rest RTP payload.

Upstream Message Receiver. We use Gtalk as the upstream channel, although our system in no way depends on encrypted indirect channels like Gtalk. We implemented a simple Gtalk client using a python API `xmpppy` [21] to send and receive Gtalk messages. Each Gtalk message contains a URL, the user’s IP address, and a task number (also contained in the RTP payload). The upstream message receiver forwards the Gtalk message to the prefetching proxy by sending a UDP packet, and then the prefetching proxy will start downloading the webpage according to the URL.

Prefetching Proxy. Since each CensorSpoofer client only sends one URL (instead of separate HTTP requests) to the spoofer, the spoofer needs to prefetch the whole web-

page on the behalf of the client. This means that the spoofer needs to first download the html file, parse it to figure out the missing objects, and then send separate HTTP requests to fetch these objects, and finally send all the downloaded data to the client over the RTP channel. We built a prefetching proxy (PFP) for this purpose. Instead of implementing a html parser and fetching embedded objects (which are essentially the operations of a web browser) from scratch, we use an open-source layout engine `QtWebKit` [22], which is a port of the popular `WebKit` layout engine into the `Qt` application development framework. We choose `QtWebKit` because it provides a simple `QtWebPage` type that significantly reduces our development effort. Given a URL to load, a `QtWebPage` performs all the necessary network operations, including parsing, Javascript execution, etc., in order to render the webpage. The PFP obtains all the raw HTTP responses for HTTP requests that the `QtWebPage` makes. As soon as PFP receives a full HTTP response, it sends the request-response pair to the client over the RTP channel. When the `QtWebPage` finishes loading the entire webpage, the PFP sends an “End-of-Page” marker to the client, to inform that there will be no more request-response pair for this webpage.

B. THE CLIENT PROTOTYPE

To avoid the censor detecting CensorSpoofer users based on the fingerprint of their softphones, we do not implement our own softphone for the clients; instead, we let the client use any existing softphone to access CensorSpoofer. Again, we use PJSUA for the client prototype.

When running the client, PJSUA is first launched to register the user’s SIP ID. Most softphones (including PJSUA) do not support making calls outside the user interfaces. In order to call the spoofer automatically inside our client program, we use `tcpdump` to pre-record the INVITE and ACK messages, and send them in an ongoing SIP initialization session (the ACK message needs to be updated according to the received OK message). Once the SIP initialization is finished, the client creates a UDP socket to receive RTP/RTCP packets from the spoofer and send RTP/RTCP packets to the dummy host. The client uses the pre-shared key to decrypt received packets and stores the decrypted blocks into a buffer. Once λ blocks in a group are received, the client uses the XOR-based decoder to recover the original group.

We implemented a client-side HTTP proxy (CSP) to handle HTTP requests made by the user’s browser and HTTP responses received from the RTP channel. When the CSP receives the first HTTP request for a page, it forwards the URL of the page to the spoofer via the Gtalk channel, but will not forward subsequent requests for other objects of the page. Instead, the CSP will “collect” in memory the HTTP request-response pairs received from the spoofer, and will serve to the client’s browser the appropriate HTTP responses from its memory when the browser makes a HTTP request. We note that any web browser supporting HTTP proxies, such as Mozilla Firefox, can use the CSP because the CSP provides an HTTP proxy compliant interface. Therefore, we do not have to modify existing web browsers or implement a new one. However, for ease of automating experiments, we implement a minimal browser application (totalling 150 lines of code) that is simply a wrapper around `QtWebPage` to load the webpages. This browser application also outputs various statistics useful for our evaluation.